

# COAX PRODUCT DATASHEET

## BNC STRAIGHT CRIMP / CRIMP PLUG

### 10-005-A0-BC



images for illustration purposes only

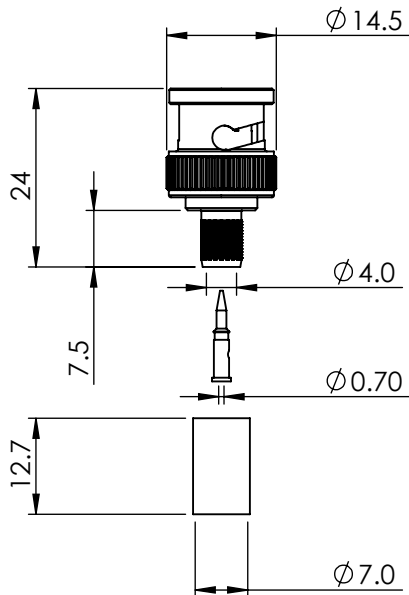

### Suitable for Cables:

(BC) BT2003, PSF 1/3

### Stripping Dimensions

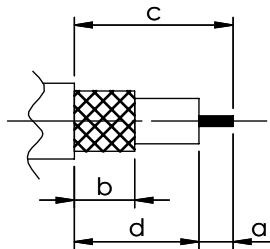

a = 4.0 mm  
b = 8.0 mm  
c = 16.0 mm  
d = 12.0 mm

### Assembly Procedure: AP001

### Tooling

Centre Contact: Hex 1.72mm A/F Tool No: 336A

Crimp Sleeve: Hex 6.50mm A/F Tool No: 336A

### Environmental Specification

Operating Temp: -30 to +70 Deg C.

IP Rating (Mated): IP 64

### Electrical Specification

Impedance: 75 Ohm

Frequency: 0-1 GHz

Dielectric W/V: 1500 Veff

Insulation res: 5000 M-Ohm

### Mechanical Specification

Contact Retention: 10 N min

Cable Retention: 120 N min

Mating cycles: 250

Weight: 9.94 g

### Connector Interface

image for illustration purposes only

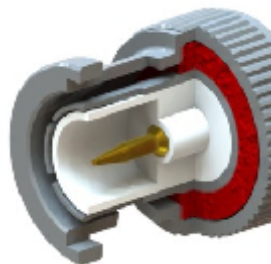

| ITEM | DESCRIPTION          | MATERIAL | PLATING |
|------|----------------------|----------|---------|
| 9    | CRIMP SLEEVE         | BRASS    | NICKEL  |
| 8    | CENTRE CONTACT       | BRASS    | GOLD    |
| 7    | BODY                 | BRASS    | NICKEL  |
| 6    | WASHER               | Fe       | NICKEL  |
| 5    | SPRING               | SK5      | NICKEL  |
| 4    | INNER RETAINING RING | SK5      | NICKEL  |
| 3    | GASKET               | SILICONE | N/A     |
| 2    | INSULATOR            | DELTRIN  | N/A     |
| 1    | BAYONET CAP          | ZINC     | NICKEL  |

|            |              |  |                               |           |            |
|------------|--------------|--|-------------------------------|-----------|------------|
| <b>A4</b>  | SHEET 1 OF 1 |  | DIMENSIONS ARE IN MILLIMETRES |           |            |
| REVISION : | A00          |  | NAME                          | SIGNATURE | DATE       |
| DRAWN      |              |  | GE                            |           | 09/05/2012 |
| ISSUE :    | 2            |  | CHK'D                         | IG        | 10/05/2012 |
| APPV'D     |              |  |                               |           |            |

THE INFORMATION IS GIVEN AS AN INDICATION ONLY AND IS SUBJECT TO CHANGE WITHOUT NOTICE. IN THE CONTINUAL GOAL TO IMPROVE OUR PRODUCTS, WE RESERVE THE RIGHT TO MAKE ANY MODIFICATIONS NECESSARY WITHOUT PRIOR NOTICE.